

### HARMONIA SERIES

### Toilet roll holder with shelf



**AI2005B**  
Black finish



**AI2005C**  
Bright finish



**AI2005CS**  
Satin finish

#### General description

- Bathroom toilet roll holder with flat shelf to hold mobile phones, keys, watches, air-fresheners, etc., made of AISI 304 stainless steel, from Mediclinics' Harmonia series.
- With a modern and intelligent design, this toilet roll holder has an arm with a stopper to prevent the toilet roll from falling off during use.
- This toilet roll holder is one of the essential bathroom accessories to install in your home, and can also be used in public-use bathrooms, such as hotels, bars, restaurants, offices, etc.
- Made with high-quality, durable and anti-corrosive materials.
- Suitable for most sizes of household toilet rolls.
- This bathroom accessory includes stainless steel hardware for installation on brick walls.

#### Components and materials

- **AI2005B**: toilet roll holder with shelf made of AISI 304 stainless steel black finish.
- **AI2005C**: toilet roll holder with shelf made of AISI 304 stainless steel bright finish.
- **AI2005CS**: toilet roll holder with shelf made of AISI 304 stainless steel satin finish.
- **PAPER ROLL AXIS**: made of AISI 304 stainless steel. Designed with an end stopper to prevent the roll of paper from falling out during the operation. Fixed to the wall bracket through welding.
- **WALL-SHELF BRACKET**: of one-piece 90° bent, made of 1.5 mm thick AISI 304 stainless steel sheet. The shelf has a 45° fold at its end to avoid falling objects deposited on it.

#### Technical specifications

<b>Dimensions</b>	160 x 95 x 103 mm
<b>Wall-shelf bracket thickness</b>	1.5 mm
<b>Net weight</b>	400 g

#### Dimensions

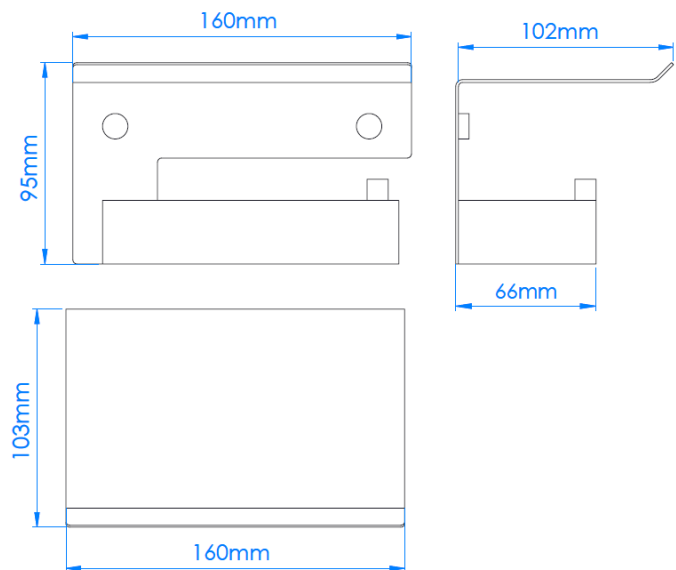

Dimensions: ± 4%